

# NUOZONE



## 5 GRAM OZONE GENERATOR

nuozone

# Table of contents

<b>General Information and Specifications</b> .....	2
<b>Safety Precautions &amp; Warnings</b> .....	3
<b>Preparations and Connection</b> .....	4
<b>Dimensions</b> .....	4
<b>Controls</b> .....	6
<b>Operation</b> .....	7
<b>Health Warnings</b> .....	8
<b>Cleaning &amp; Maintenance</b> .....	9
<b>Contact Details</b> .....	11

## General Information

The Nuozone 5 grams Ozone Generator is a new high power ozone odour eliminating system which removes odour and purifies areas by utilizing electrically activated Tri-atomic oxygen (O<sub>3</sub>). Areas of use include fire and flood restoration, cleaning, document restoration, destruction of mould and bacteria, sewage, tobacco, food preparation, combustion and most other organic odours such as (Glue and Paint) Emissions.

Incorporating the most advanced Dielectric Barrier Corona Discharge technology the durable unit is highly efficient and able to operate in harsh environments and is by far the most powerful in its class yielding up to 5 grams/hour \* and does not require a supplementary oxygen supply.

The ultra-portable design enables its easy incorporation into regular maintenance schedules to prevent further accumulation of unpleasant smells. The Nuozone 5 grams Ozone Generator requires only occasional routine servicing for years of service. The easily detachable electrode allows for simple cleaning with warm soapy water, which takes only minutes. A variable timer on the machine can be set up to **30** hours. The new concept is totally modular and replaceable, comprising power supply, high voltage unit and double Barrier Corona Discharge glass electrode

## Specification

Ozone Output:

\*5 grams of ozone/hour +/-10% at ambient temperatures of 25 °C at a humidity of 80% at sea level atmospheric pressure.

Fan Discharge 340 cubic metres/hour

Power 110 or 220 volts (depending on specification) The unit uses approximately 125 watts at 230 volts **AC** 50/60 cycles (0.6 amps.)

Fuse 2 Ampere,

Safeguard Micro switch interlock

Timer 300 hours,

Service interval Hour Counter

Net Weight 6 kilo

## Safety Precautions & Warnings

### ATTENTION!



This system is equipped with a ventilation inlet and a ventilation outlet. DO NOT BLOCK inlet/outlet or place foreign objects in their vicinity.



Do not expose this equipment to rain or moisture. Should any liquid come into contact with the system, unplug it and have it serviced by qualified personnel before operating it further.



Unplug the system from power socket when it is not in use. When unplugging, never pull the plug by the cord itself. DO NOT disconnect cable cord from mains socket before the operation of the system is completed.



DO NOT enter the treated room during the operation of the system, or before all ozone in the room has dissipated to health and safety standards. Remaining in the treated area while unit is in operation or entering before completion of cycle may be hazardous to your health. You must leave the room immediately and seal entrance to prevent activated oxygen leakage.

Ozone can adversely affect indoor plants, and damage materials such as rubber, electrical wire coatings, and fabrics and art work containing susceptible dyes and pigments

### ATTENTION !!

**This unit is supplied with a grounded cable. Attempting to overpass the ground or connecting the unit to ungrounded mains is strictly prohibited.**

**Under no circumstances should the unit be operated with the outer panels loose or missing.**

**Prior to removing the panels or air filters for maintenance, always disconnect the unit from the mains power.**

**With the exception of the glass electrode and dust filter, there are no user serviceable parts under the cover of the system; removal of these parts by unauthorized personnel will result in voiding the WARRANTY!**

## PREPARATIONS AND CONNECTIONS

### Assembly and Electrode Installation

**BEFORE RUNNING THE MACHINE REMOVE THE SYSTEM COVER AND INSTALL THE GLASS ELECTRODE**

**RUNNING THE MACHINE WITHOUT THE ELECTRODE MAY SERIOUSLY DAMAGE THE MACHINE**

The system cover is removed by unscrewing the retaining screws and sliding the cover to the rear – **DO NOT LIFT COVER UPWARDS OR YOU WILL DISTORT THE METALWORK**

**NOTE:** The electrode can only be inserted into the high voltage unit one way. The electrode is held in the unit by 2 stainless steel screws. The electrode will not sit flush in the high voltage unit if reversed and the screws will not secure properly. (Insure that the moisture gasket is correctly installed if removed. It is unidirectional and the two longest sides are of different width and will only install one way.) **DO NOT FORCE ELECTRODE INTO RETAINING CONNECTOR** – If the electrode does not fit flush, gently remove electrode, rotate 180° then refit. The electrode is glass and should be treated accordingly.

The high voltage unit and electronic unit must then be connected together using the installed male and female fast connectors.

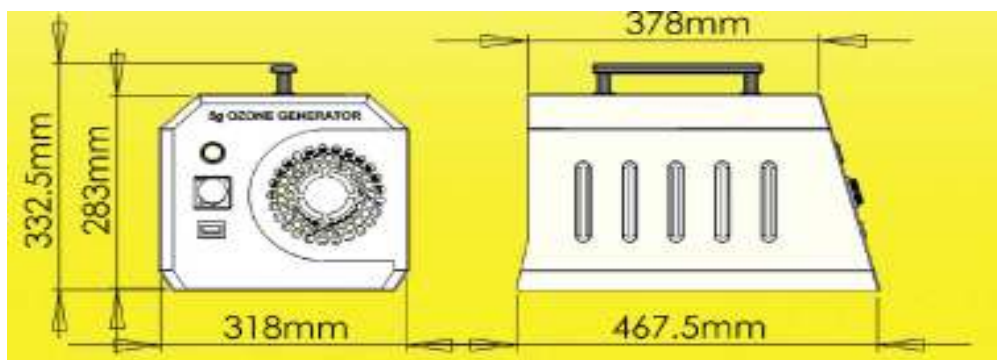

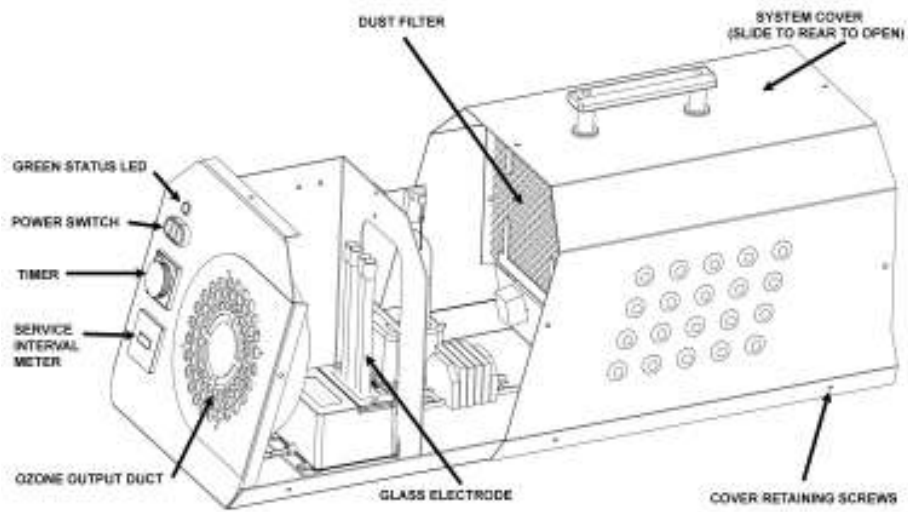

### COVER REMOVAL

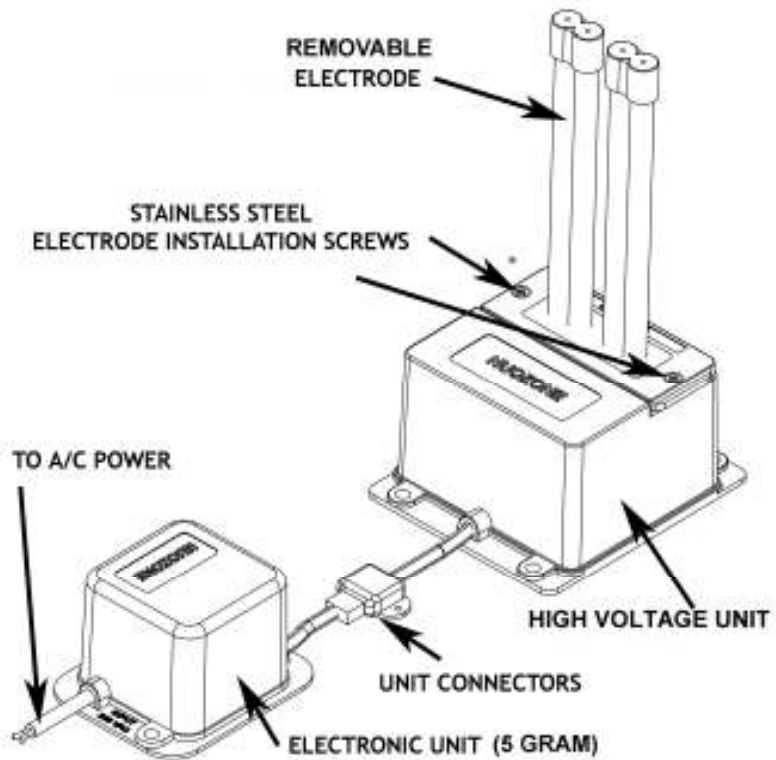

### ELECTRODE INSTALLATION

## CONTROLS

### TIMER



The timer has 14 field selectable time ranges from 0↔0.2 seconds to 0↔300 hours and can be set by carefully inserting and turning a thin flat screwdriver in the timer reset hole (BOTTOM RIGHT). The display will then change to the following ranges: 0↔1.2 seconds/3 sec/12 sec/30 sec/1.2 minutes/30min/1.2 hours/3h/12/h/30h/120h/300h

Once the chosen range has been selected, the duration of ozone generation can be set by carefully turning the dial to the required time. For normal purposes the 0↔ 3hours, 0↔ 12hours or 0↔30hours range should suffice.

**Do NOT confuse the timer reset hole (lower right) with the service hole (upper right) marked "A" which MUST NOT be reset**

### SERVICE COUNTER

The equipment is provided with a hour service counter

### GREEN STATUS LED

A green status LED will be visible when the machine is generating ozone

### POWER SWITCH

The power switch  is situated on the front panel. Red is OFF and Green is ON

## OPERATION

**Connect** power cord to socket on system outer rear panel (bottom) and only then connect it to the power source socket.

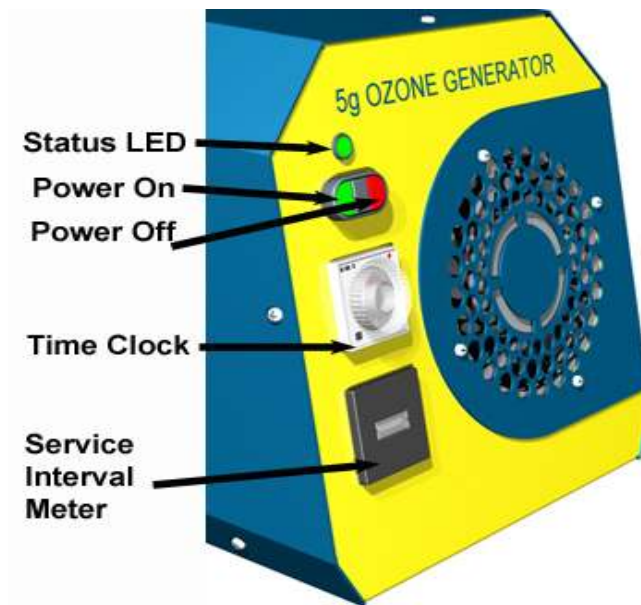

**PRESS THE GREEN BUTTON  
TO START OPERATION**

**THE MACHINE WILL START AND RUN FOR THE DURATION SELECTED ON THE  
TIMER**

**THE GREEN STATUS LED WILL LIGHT TO SHOW THE MACHINE IS RUNNING**

**Note: Choice of length of ozone generation cycle should  
correspond with the odour level in the room.**



**PRESS THE RED BUTTON  
TO STOP/RESET OPERATION**

**Before relocating the system to another room or for storage, make sure to disconnect the power cord from mains socket.**

## **HEALTH WARNINGS**

**You must leave the room immediately and seal entrance to prevent ozone leakage.**

**Remaining in the treated area while unit is in operation or entering before completion of cycle may be hazardous to your health.**

### **CAUTION!!!**

**OZONE IS A POWERFUL OXIDISER. USE THIS EQUIPMENT WITH CARE IN UNINHABITED AREAS ONLY. READ ALL OPERATING INSTRUCTIONS BEFORE USING THIS MACHINE.**

**RE OCCUPY TREATED ROOM ONLY AFTER SET OPERATION TIME HAS ELAPSED.**

**DO NOT ATTEMPT TO ENTER THE ROOM WHILST MACHINE IS IN OPERATION.  
VENTILATE ROOM AFTER USE**

## **ATTENTION!**

**If at any time you need to reset setting press:  
STOP button (red)**



### **WARNING – IN EMERGENCY**

**IN THE EVENT OF MAJOR POWER FAILURE OR DO NOT RE-ENTER THE ROOM UNTIL SUFFICIENT TIME HAS ELAPSED FOR OZONE CONCENTRATION TO BE AT SAFE LEVELS.**

Ozone has a half life of around 30 minutes. As a guide, a 24 hour production of Ozone will take around 12 hours to naturally decompose to a safe limit, and 48 hour production of Ozone will take around 24 hours to decompose to a safe limit before the area can be safely re-occupied.

**IN AN EMERGENCY USE AN ACTIVATED CARBON FILTER BREATHING MASK TO GAIN ACCESS TO THE AREA**

## 1. Cleaning & Maintenance

Disconnect the unit from electrical mains prior to any cleaning and maintenance procedure.

The amount of time between cleaning will depend upon the amount and type of use. The harder the service, the more often the maintenance is required. The Nuozone 5 grams Ozone Generator is designed for indoor use only, and should be cleaned every 3-4 months. Dirt (from electrostatic action) coupled with moisture (humidity) can foul the electrodes, causing dirt to adhere to the electrodes. For fire restoration applications, check after every few of jobs to determine if cleaning is necessary. Dry cleaners, hotels, motels, and vehicle applications should require cleaning approximately every 2-3 months if used often. Check your ozone equipment more often initially to determine if you need to go longer or shorter periods between maintenance. Below is a list of important operating factors that increase the frequency for cleaning:

- Unit operated 24 hours a day
- Unit operated 365 days a year.
- Unit mounted outdoors.
- Unit operated in an area of excessive dust or dirt.
- Unit operated in a high moisture or humidity environment.

An easy way to determine if your machine is dirty is to listen to it. The blower will come on, and it has a high volume fan sound. You will also hear the sound of corona formation which is the result of a high voltage causing the air to ionize. The sound is a low tone hissing or buzzing. A really dirty unit may have no corona sound, or if a unit has too much moisture in it, a snapping or arcing sound occurs. Please shutdown the unit and perform the necessary cleaning.

Routine maintenance consists of cleaning the air filter, cleaning the cabinet interior, cleaning the glass electrode, and checking the blower motor.

The exterior of the unit should be cleaned with a damp non abrasive cloth.

## Removing the Dust Filter

Behind the rear grill there is dust filter that should be removed from time for cleaning. Remove the system cover then remove the dust filter.

**The installation and maintenance of a suitable dust filter will preserve the efficiency of the electrode.**

1. Verify that unit is not connected to power socket.
2. Unscrew system cover and slide to rear and remove. (See diagram)
3. Unfasten filter fasteners on the rear of the grill panel
4. Pull out mesh dust filter and place under running water.
5. Wash it out thoroughly and dry it before reinstalling in the unit. The filter can also have some of the dirt blown with air hose, but be careful not to damage the filter media. (Replace filter if necessary.)
6. Dry filter thoroughly.
7. Fasten filter to rear of grill panel and subsequently replace and fasten system cover with screws.

## CLEANING ELECTRODES

To prevent dirt being electro statically drawn to the electrode and coupled with humidity, subsequently adhering to the glass, it is important that the electrodes, which are easily removable, are carefully cleaned on a regular basis. Electrode performance should then remain constant for at least a whole year (7000 hours approx.).

1. Verify that unit is not connected to power socket.
2. Unscrew system cover and slide to rear and remove. (See diagram)
3. Clean the electrode assembly in place if possible. Check to see if it has become cracked or broken. Begin by using a moist cloth to wipe off and between the glass cylinders removing any dirt or contaminates. Next dry with soft, dry cloth that is lint free. Be careful not to break the glass insulator tubes. If necessary the electrode assembly can be removed via the two screws holding it to the base of the High Voltage transformer module. Try not to handle the electrodes with bare hands to prevent oils from coming in contact with glass. Dry the tubes by wiping down before re-installing.
4. If the electrode needs to be removed from the High Voltage transformer, follow the instruction in the section "Assembly and Electrode Installation"
5. After carefully cleaning and replacing electrode, replace and fasten system cover with screws.